

Sustainability in commercial laundering processes

Module 6
special aspects
Chapter 3 a

Combination of different systems to treat waste water and heat



- Biological treatment systematic

- Rotating discs reactor
 - Application
 - Special features
 - Functionality
 - Case Study (St. Joris)

This chapter is a contribution of ECOLAB

After finishing this chapter you will

- Have an overview of biological treatment systematic and be able to explain
- Know the applications of a rotating discs reactor
- Know and be able to explain the functionality of a rotating discs reactor

Biological Treatment Systematic

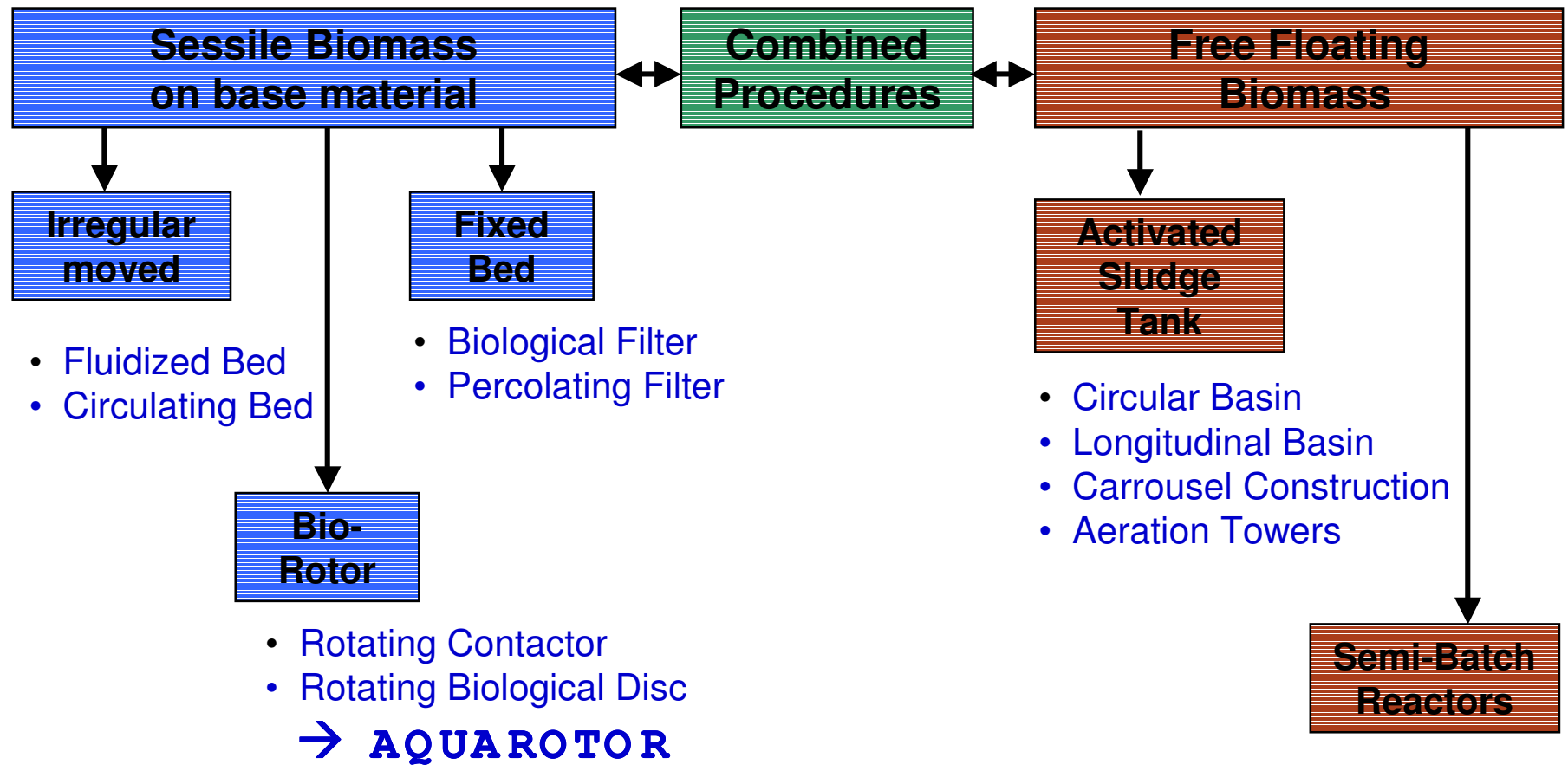



Education and Culture

Leonardo da Vinci

A Biological Treatment Unit to Reduce COD and BOD Values and to Fulfil legal Requirements



- Biological cleaning of industrial effluent - polluted with organic ingredients from
 - Food industry
 - Pharmaceutical industry
 - Car industry
 - Textile industry
 - Professional laundries

! Suitable for treatment of effluent from most laundry classifications

AQUAROTOR Compact Unit Installation



Leonardo da Vinci

... Inside a building



... Outside

- Reduction of BOD and COD values in laundry effluent
 - BOD removal ratio: up to 98%
 - COD removal ratio: up to 85%

- Avoid additional costs for heavily soiled effluent

- Compliance to the regulations for discharging effluent

- Optional: Re-use after treatment

AQUAROTOR - Special features



Leonardo da Vinci

- Reduction of COD and BOD values in combination with water recycling
- Simple, rigid and highly durable construction
- Lowest running costs compared to alternative systems
- Low maintenance requirements
- High tolerance to waste water load fluctuations
- Modular construction - small space requirements



AQUAROTOR - Functionality

- The rotary disc unit is rotated within the water tank at low speed
- Several hundred highly durable, polypropylene discs are turned repeatedly within the tank between the water and air. The effluent in the water tank flows through the unit while making contact with the disc surfaces

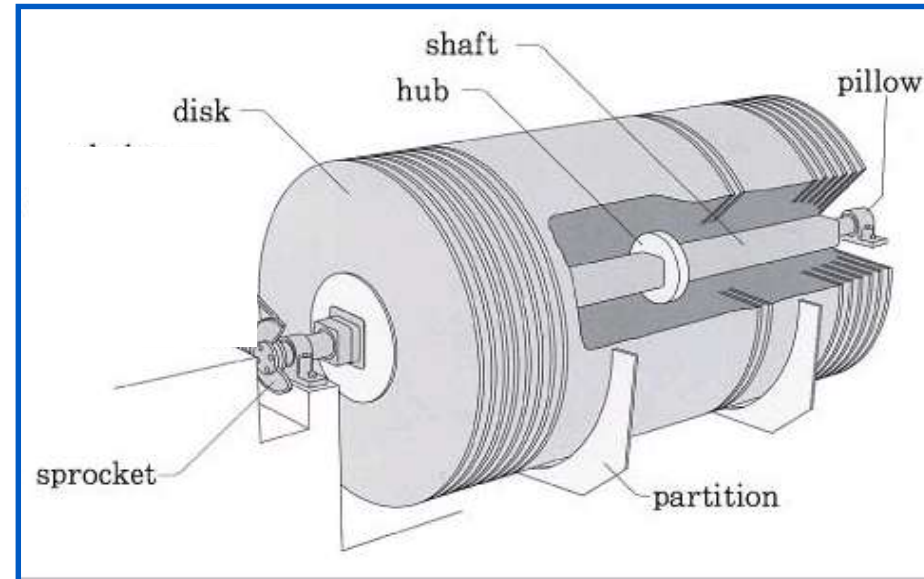

Functional drawing



- The biological film of microbes formed on the surface of the discs respire oxygen while rotating through the air. While diving through the waste water the organic materials are absorbed and decomposed by the microorganism
- High density of biological material on the surface of the discs and the construction in several cascades, makes biodegradation that efficient

AQUAROTOR – Case Study St. Joris



Education and Culture

Leonardo da Vinci

- Healthcare laundry in Belgium with daily production of max. 20 tons/day
- Maximum water intake was capped at 200 m³/day
- No connection to the municipal sewage plant
- Ecolab installed a system in order to meet the discharge limits and to save water and energy
- Plant in operation since 09/2000
- Several water samples were taken from influent, after first cascade and from effluent

AQUAROTOR – Flow diagram St. Joris

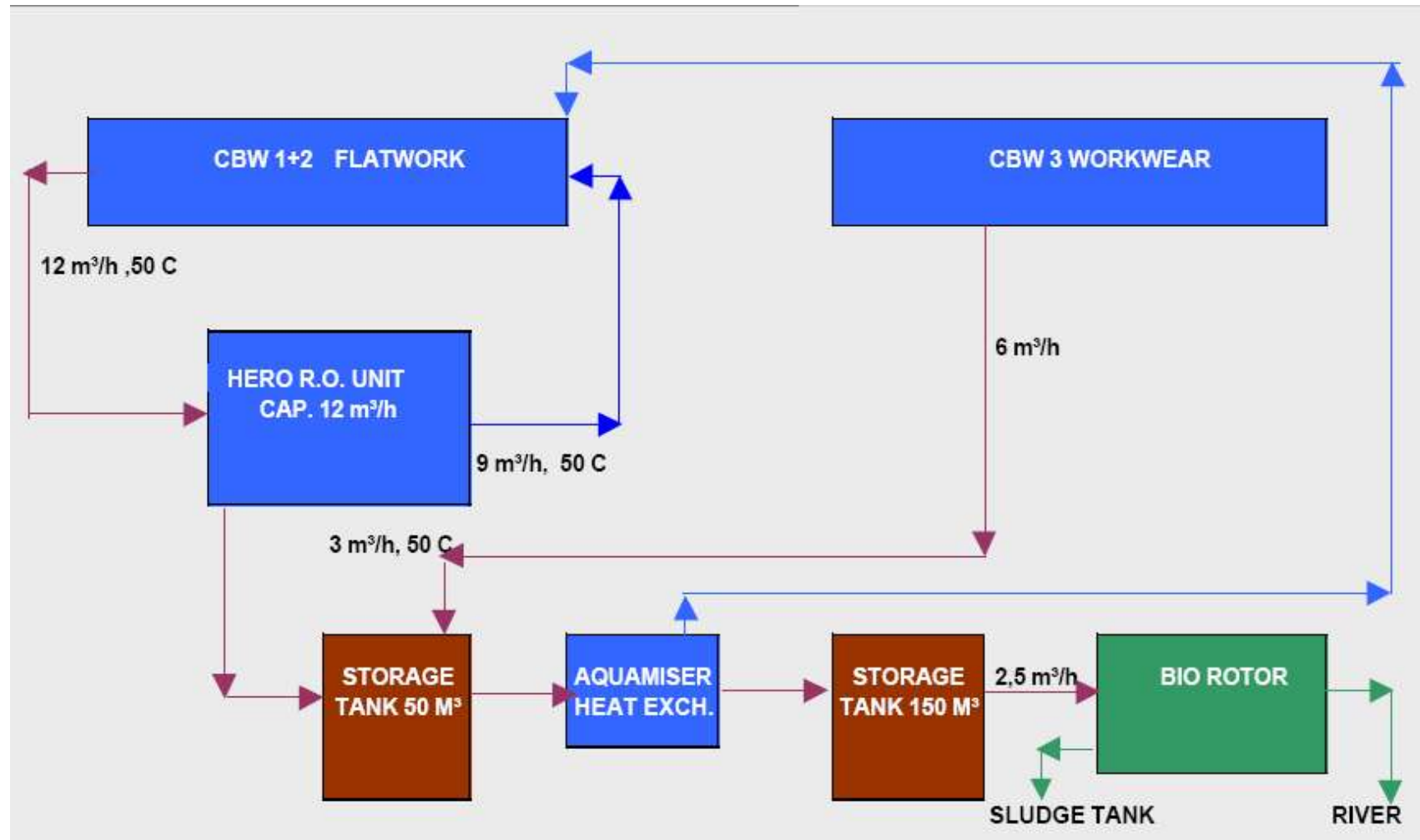

Aquarotor St. Joris: Decomposition of Organical Material
(Data from 2002)

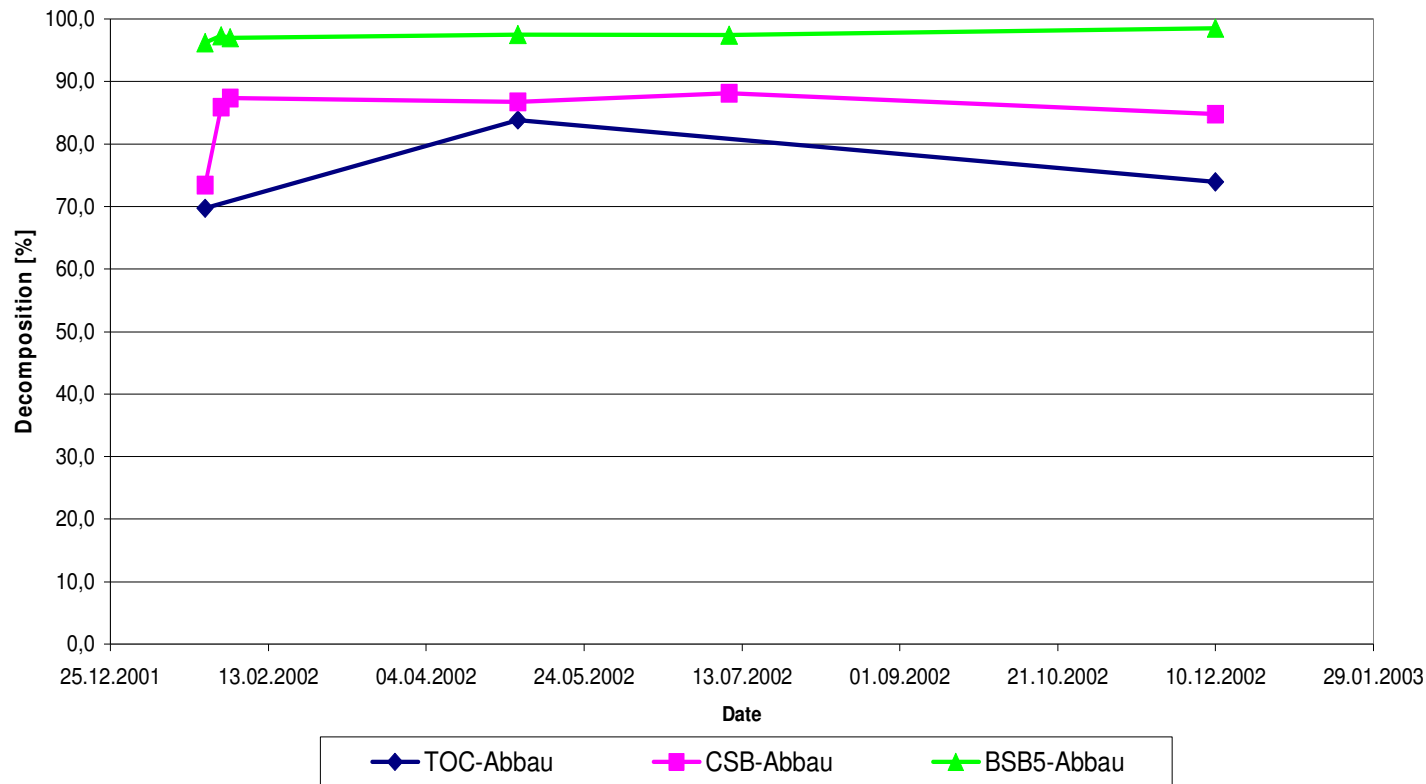



Education and Culture

Leonardo da Vinci

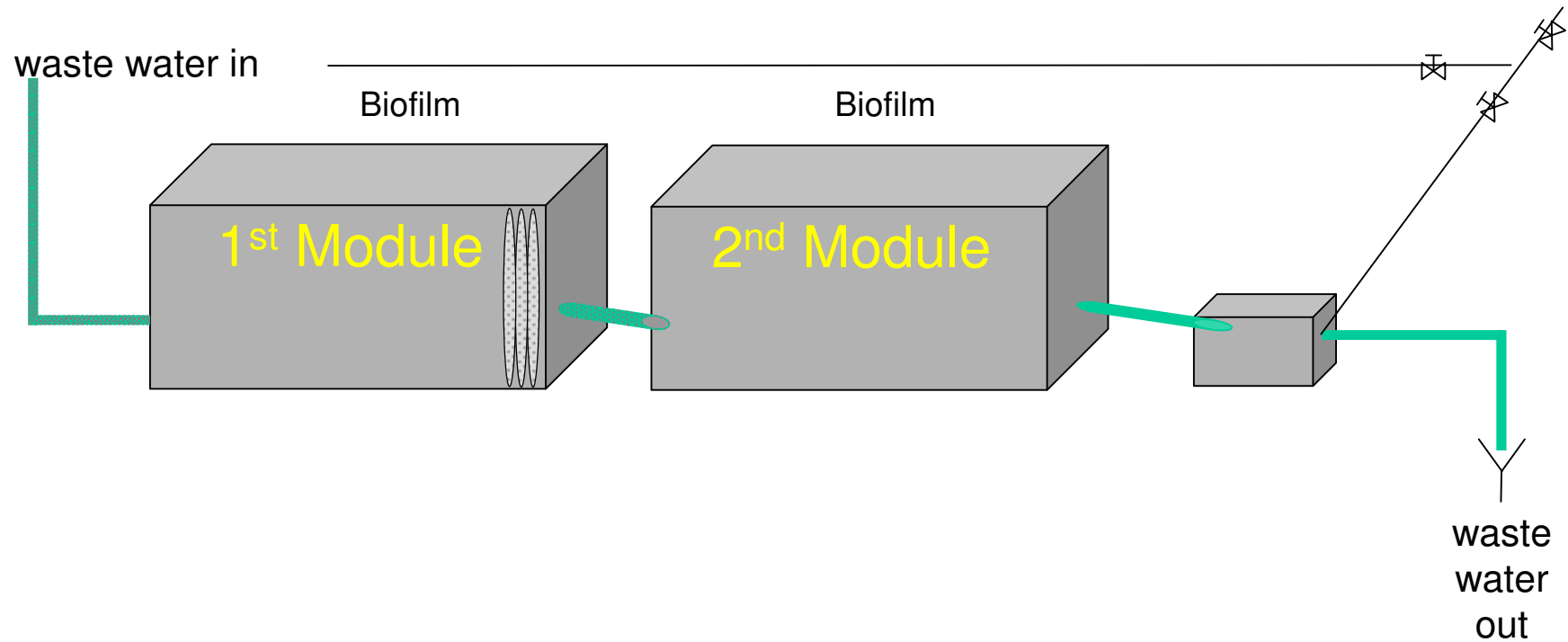

Reduction of waste water load



Education and Culture

Leonardo da Vinci

<i>C.O.D.</i>	1210 mg/l	- 43%	685 mg/l	- 42%	394 mg/l	- 67%
<i>B.O.D. 5</i>	730 mg/l	-73%	200 mg/l	-64%	71 mg/l	-90%
<i>Anionic Surf. fat.</i>	12,63 mg/l	-25%	9,51 mg/l	-35%	6,22 mg/l	-51%
<i>Non-ionic Surf. fat.</i>	110 mg/l	-79%	23 mg/l	-69%	7,2 mg/l	-93%
<i>Suspended solids</i>	312 mg/l	-40%	187 mg/l	-60%	75 mg/l	-76%
<i>Total Hydrocarbon</i>	1,41 mg/l	-34%	0,93 mg/l	-77%	0,21 mg/l	-85%
<i>Daphnia test</i>	25 équitox/m ³	-85%	3,7 équitox/m ³	-70%	1,11 équitox/m ³	-96%
<i>Microtox test</i>	84,03 UTM	-94%	4,73 UTM	-72%	< 1,33 UTM	-98%
<i>Algae growth Inhibition test</i>	2,67 équitox/m ³	-28%	1,93 équitox/m ³	-44%	1,08 équitox/m ³	-60%

Energy Optimiser[®] heat exchanger



Leonardo da Vinci

- Specially designed for difficult waste water conditions in professional laundries
 - No down time due to blocked heat exchanger
- Self-cleaning unit
 - Rotating heat exchange element
 - No down time for cleaning
- Specially treated surface
 - No fouling
 - Meets hygienic requirements

