

HIGH SPIN WASHER EXTRACTORS

**HC 60**  
**HC 65**  
**HC 75**  
**HC 100**  
**HC 135**  
**HC 165**





# HC 60 - HC 65 - HC 75 - HC 100 - HC 135 - HC 165

## **New look**

- Matt door: uniform look of the front
- Ergonomic doorhandle: easy to handle and interchangeable with the previous model
- New front panel: uniform with IPSO CD Dryer range



## **Door**

- Large door diameter: easy loading & unloading
- Over-dimensioned hinges
- Stainless steel with a matt finish!



## **Frontal soap dispenser**

- Frontal 3 compartment soap box
- Optionally available on all models!



## **HC-range: totally freestanding**

- Thanks to unique position of the counterweight and unique suspension system
- The HC-machines are put on "feet" and don't have to be anchored to the ground
- Extra advantage: The HC-machines can easily be installed on wooden floors, floors with floorheating, in older buildings,...

## **Extraction vs residual moisture**

- The higher the G-Force during extraction, the lower the water retention of the fabrics being processed
- A higher G-Force will reduce the gas or electricity used during the drying process
  - > reduced drying and finishing time
  - > reduced linting
  - > extended linen life
- High speed extraction can eliminate preconditioning of items to be ironed
  - > energy save
  - > increased production

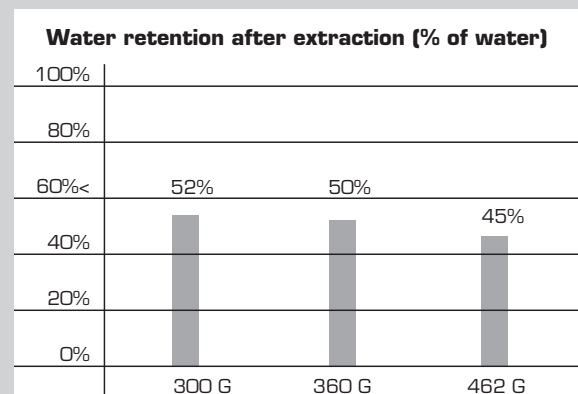

## **MICRO 20**

- With plugs: easy to service
- Up to 99 programmes
- Temperature and water level freely programmable
- Time delay start-up feature
- Micro 20 coin: up to 20 programmes

## **SIGMA**

- Same features as Micro 20
- Infra-red port: easy downloading of programmes from laptop
- Serial port RS 485: machines can be put in a network
- 1000 programmable sections divided over 100 programmes
- Sigma-coin: alarm can be activated



## **PS40**

- Freely programmable
- 10 standard programmes
- 40 freely programmable wash programmes
- Temperature, water level, cycle time and rpm freely programmable
- Connection up to 12 pumps for liquid soap possible
- Control of 2 drain valves (option)
- Infra-red port facilitates the downloading of programmes

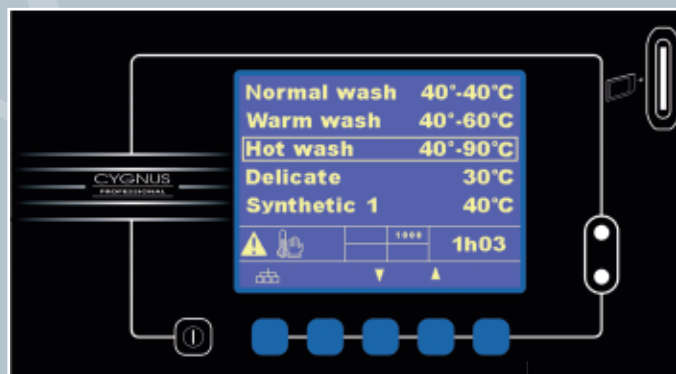

## **Cygnus Professional**

Cygnus Professional allows modification of wash data & parameters at any time, even during the wash cycle.

- Large LCD-display: easily understandable
- Possibility to consult the complete history/logbook of all wash facts on the display
- Extensive help-function: extensive assistance to solve the error

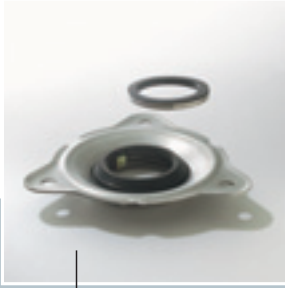

### **Axial sealing**

- Proven IPSO concept
- Made out of graphite

### **Poly V-belt**

A unique concept of self-tensioning belt:

- Elastic
- Self tensioning
- Easy to install/replace
- Longer life span
- Less noise



### **Drain valve in front directly under the tub**

- Less water consumption
- Easily accessible from the front
- Counterweight does no longer need to be removed for cleaning of drain valve
- Self-cleaning water level hose

### **Standard inverter drive**

- Washing and spin speeds freely programmable
- Rotation and stop time freely programmable from 0,1 till 60 sec
- Low sound level
- Less unbalances
- Less current peaks
- ⇒ Longer life span of your IPSO washer extractor



### **Bearing house**

- Cast iron bearing house
- Long life span of the bearings



### **Connection from the soap box to the tub**

- Connection at the back of the tub
- No aggressive detergents directly on the linen
- Simple and efficient connection of the soap pumps

**front view HC 60**

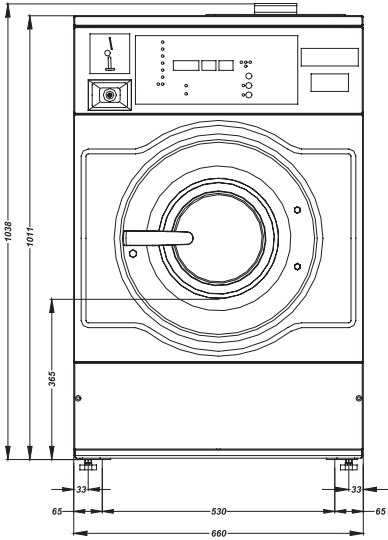

**front view HC 65-75-100**

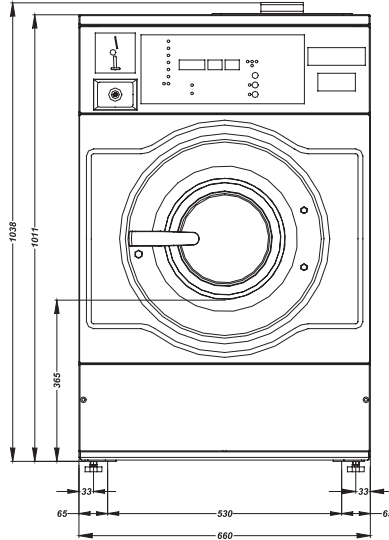

**front view HC 135-165**

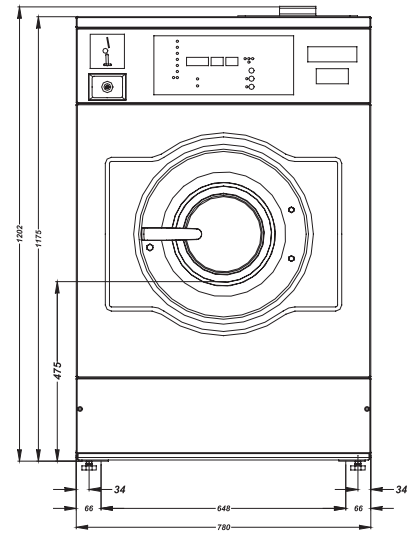

**rear view HC 60**

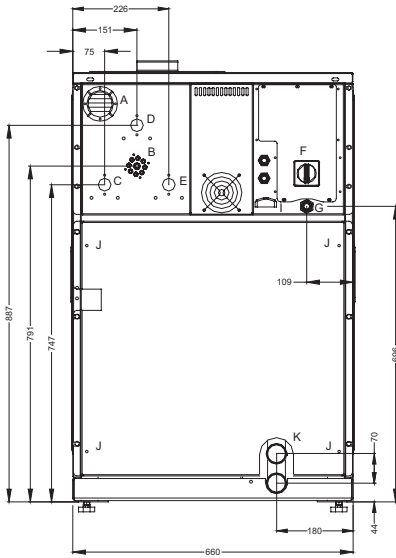

**rear view HC 65-75-100**

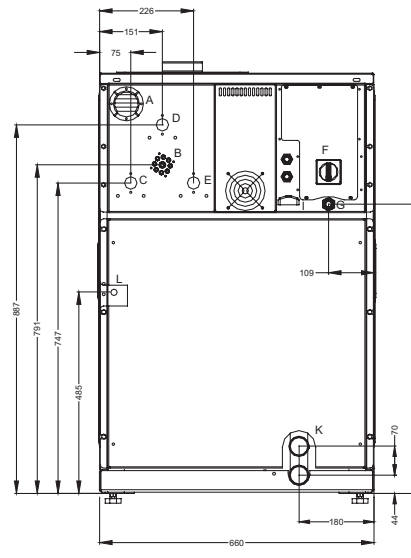

**rear view HC 135-165**

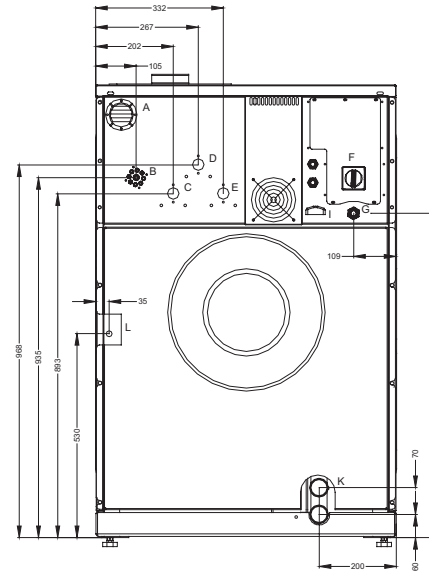

**side view HC 60**

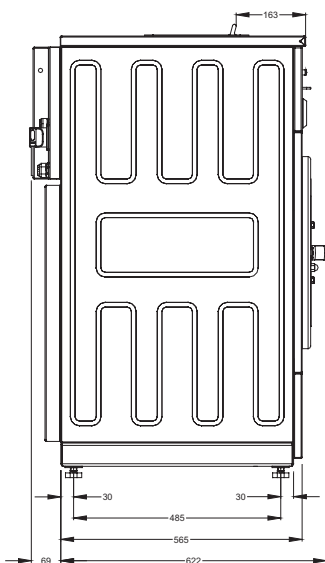

**side view HC 65-75-100**

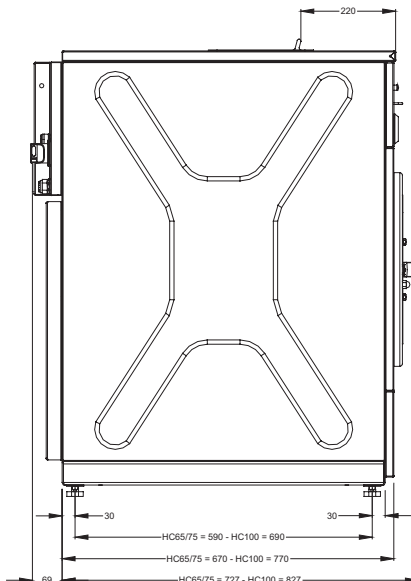

**side view HC 135-165**

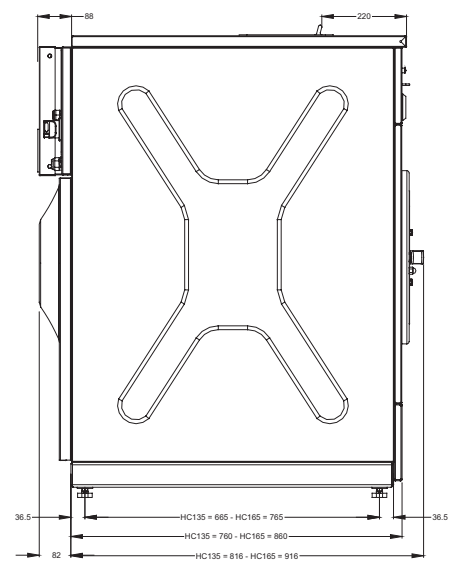

A. Ventilation soap dispenser  
B. Liquid soap connections  
C. Hard water connections 3/4"

D. Warm water connections 3/4"  
E. Soft water connections 3/4"  
F. Connections clamps

G. Electrical connections  
I. Ventilation tub

J. Bolt patterns for fixation of the machine  
K. Drain valve

# TECHNICAL SPECIFICATIONS HC 60 - 65 - 75 - 100 - 135 - 165

	HC 60	HC 65	HC 75	HC 100	HC 135	HC 165						
Cylinder: Capacity 1/9 (kg)	6,1	7,2	8,1	10,5	14,6	18,3						
Capacity 1/10 (kg)	5,5	6,5	7,3	9,5	13,2	16,5						
Volume (L)	55	65	73	95	132	165						
Diameter (mm)	530	530	530	530	650	650						
Depth (mm)	250	295	330	440	400	500						
Perforations diam (mm)	3	3	3	3	3	3						
Door opening diameter (mm)	300	300	300	300	300	300						
Height to door handle (mm)	505	505	505	505	605	605						
Speed: High spin (rpm)	500-1250	500-1000	500-1000	500-1000	500-1000	500-1000						
Low spin (rpm)	250-500	250-500	250-500	250-500	250-500	250-500						
Distribution (rpm)	85	85	85	85	85	85						
Wash (rpm)	10 - 50	10 - 50	10 - 50	10 - 50	10 - 50	10 - 50						
G-force	462	296	296	296	363	363						
Kinetic energy of the cylinder (N)	1568	1186	1386	1730	2592	3240						
Dynamic bottom load (N /16 Hz)	600	600	700	750	1000	1200						
Power motor (W)	550	750	750	750	1500	1500						
Water pressure (bar)	3 - 5	3 - 5	3 - 5	3 - 5	3 - 5	3 - 5						
Hot water T° (boiler fed) (°C)	80	80	80	80	80	80						
Warm water need (L/cyclus) (boiler fed machine)	46	55	65	80	100	120						
Diameter drain (mm/")	50 / 2	50 / 2	50 / 2	50 / 2	50 / 2	50 / 2						
Drain by gravity (L/min)	80	80	80	80	80	80						
Steam connection (")	3/8	3/8	3/8	3/8	3/8	3/8						
Steam pressure (bar)	2,0 - 5,5	2,0 - 5,5	2,0 - 5,5	2,0 - 5,5	2,0 - 5,5	2,0 - 5,5						
Weight gross (kg)	198	229	233	258	355	388						
nett (kg)	184	207	211	236	325	358						
Dimensions Height (mm)	1038	1038	1038	1038	1202	1202						
Width (mm)	660	660	660	660	780	780						
Depth (mm)	622	727	727	827	816	916						
Packing dimensions Height (mm)	1170	1170	1170	1170	1350	1350						
Width (mm)	710	730	730	730	850	850						
Depth (mm)	750	840	840	950	950	1020						
Volume (m³)	0,62	0,72	0,72	0,81	1,09	1,17						
Type of heating	POWER SUPPLY - FUSES											
	230 V 50/60Hz + 3AC	400 V tri + N	230 V 3 AC	400 V tri + N	230 V 3 AC	400 V tri + N	230 V 3 AC	400 V tri + N	230 V 3 AC	400 V tri + N	230 V 3 AC	400 V tri + N
Boiler fed	16A		16A	16A	16A	16A	16A	16A	16A	16A	16A	16A
Steam heating	16A	16A	16A	16A	16A	16A	16A	16A	16A	16A	16A	16A
Electrical heating 4,2 kW	16A		16A	16A	16A	16A	16A	16A				
Electrical heating 6 kW	16A*	16A*	16A*	16A*	16A	16A	16A	16A				
Electrical heating 9 kW			25A	16A	25A*	16A*	25A*	16A*				
Electrical heating 12 kW					40A	20A	40A	20A	40A*	20A*	40A	20A
Electrical heating 15 kW									50A	25A	50A	25A
Electrical heating 18 kW									50A	32A	50A*	32A*
Electrical heating 21 kW										40A		40A
Electrical heating 24 kW										40A		40A

All specifications subject to change without notice.

(\*) Standard heating



Alliance International bvba, Nieuwstraat 146, B-8560 Wevelgem (Belgium)  
Tel +32 56/41 20 54 - Fax +32 56/41 86 74 - info@ipso.be - [WWW.IPSO.BE](http://WWW.IPSO.BE)